

FPP Industrial Meters

3" Aluminum, Model No. 5201

FPP Meters' versatile STEALTH Series is available in a variety of configurations including mechanical registration, electronic registration or non-factored pulse output flow sensors. With only two moving parts and exceptional pressure loss characteristics, STEALTH represents the ideal platform for year 2000 metering systems.

Specifications

- **Flow Rate**
20-200 GPM Viscosities to 300 CST
76-760 LPM Viscosities to 300 CST
- **Pressure**
150 PSI @ 100°F (10 Bar @ 40°C)
400 PSI @ 100°F (28 Bar @ 40°C)
- **Temperature**
300°F (149°C) RSFS only
212°F (100°C) mechanical registers
185°F (149°C) HEFS only
*other limits may apply to electronic devices
- **Viscosity**
Full nominal flow rate to 300 CST;
Up to 350,000 CST with special gears.
- **Connections**
3" NPT or BSP
Optional: 3" ANSI flange adaptors
- **Materials**
Case: Anodized Aluminum
Oval gears: Ryton® (PPS)
Shafts: 17-4 PH Stainless Steel
Seals: Viton (Teflon optional)



5201.0150.VR2
Representative Model

Industrial Performance

- **Linearity**
+/- 0.25% @ 1 CST
- **Repeatability**
+/- 0.1%
- **Resolution**
Flow Sensor: 17 PPG
Optional: 4 PPG
- **Calibration**
Mechanical: 1/10 gallon, lbs., liter & kg
Electronic: Any unit of mass or volume

Delta P & Accuracy Curves

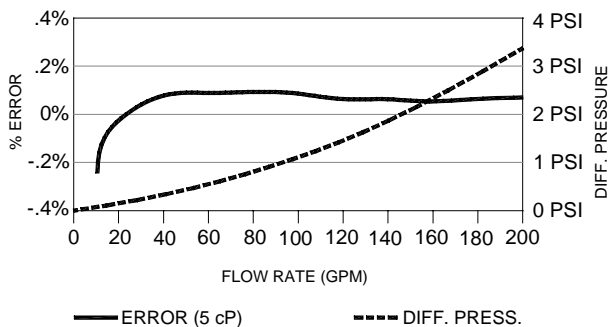

Registration Options

- Mechanical register/printer, register/preset, or register/preset/printer combination
- Battery powered electronic totalizer or register
- Electronic AC batch controllers, flow computers, and temperature compensation
- NEMA 4X & NEMA 7/4 enclosures

Accessories

- Inlet strainer for meter protection
- Air eliminator on inlet strainer
- Electric or Pneumatic preset valve
- Pulse output, analog signal & Serial Port
- Pulse Isolator/Amplifier/Splitter
- Pump control signal

Recommended protection

Inlet strainer, depending upon viscosity, with 20, 40 or 80 mesh basket

Dimensional Drawings

Model 5201.0150.VR1.SA

Model 5201.0150.RSFS

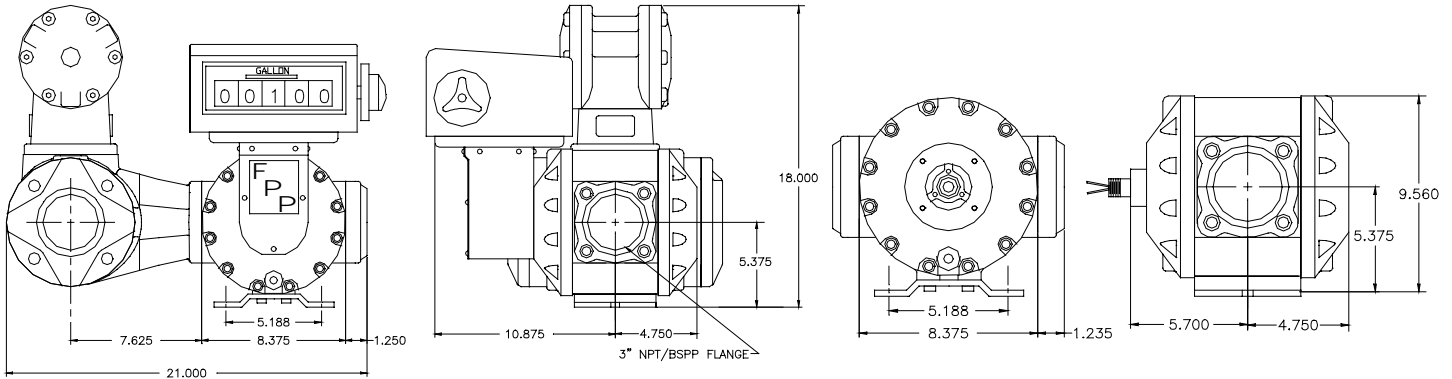

Note: All dimensions are in inches.

Warranty

Tuthill Transfer Systems ("Manufacturer") warrants to each buyer of its FPP Meters products (the "Buyer") for a period of 12 months from date of invoice or sales receipt, but in no event more than 18 months from date of manufacture, that goods of its manufacture ("Goods") will be free from defects of material and workmanship. Manufacturer's sole obligation under the foregoing warranties will be limited to either, at Manufacturers' option, replacing or repairing defective Goods (subject to limitations hereinafter provided) or refunding the purchase price for such Goods theretofore paid by the Buyer, and Buyer's exclusive remedy for breach of any such warranties will be enforcement of such obligations of Manufacturer. If Manufacturer so requests the return of the Goods, the Goods will be redelivered to Manufacturer in accordance with Manufacturer's instructions F.O.B. Factory. The remedies contained herein shall constitute the sole recourse of the Buyer against Manufacturer for breach of warranty. IN NO EVENT SHALL MANUFACTURER'S LIABILITY ON ANY CLAIM FOR DAMAGES ARISING OUT OF THE MANUFACTURE SALE, DELIVERY OR USE OF THE GOODS EXCEED THE PURCHASE PRICE OF THE GOODS. The foregoing warranties will not extend to Goods subjected to misuse, neglect, accident or improper installation or maintenance, or which have been altered or repaired by anyone other than Manufacturer or its authorized representative. THE FOREGOING WARRANTIES ARE EXCLUSIVE AND IN LIEU OF ALL OTHER WARRANTIES OF MERCHANTABILITY, FITNESS FOR PURPOSE OF ANY OTHER TYPE, WHETHER EXPRESS OR IMPLIED. No person may vary the foregoing warranties and remedies except in writing signed by a duly authorized officer of Manufacturer. Warranties or remedies that differ from the foregoing shall not otherwise be binding on Manufacturer. The Buyer's acceptance of delivery of the Goods constitutes acceptance of the foregoing warranties and remedies, and all conditions and limitations thereof.