

Dimensional Drawings: All dimensions are in inches.

Representative Models shown: TM02CD1E

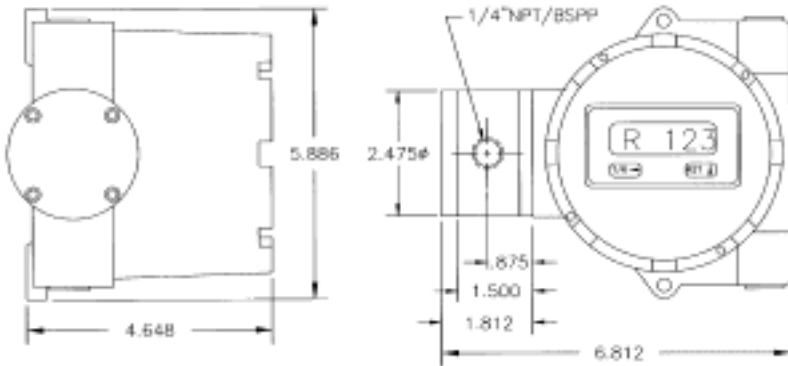

TM02CSRS

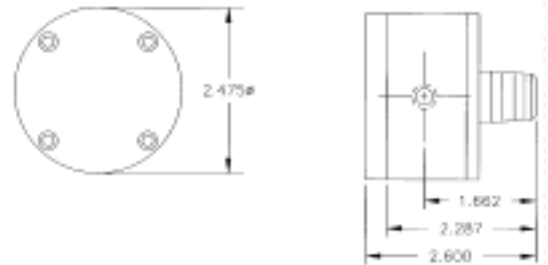

Warranty

Tuthill Transfer Systems (“Manufacturer”) warrants to each buyer of its FPP Meters products (the “Buyer”) for a period of 12 months from date of invoice or sales receipt, but in no event more than 18 months from date of manufacture, that goods of its manufacture (“Goods”) will be free from defects of material and workmanship. Manufacturer’s sole obligation under the foregoing warranties will be limited to either, at Manufacturers’ option, replacing or repairing defective Goods (subject to limitations hereinafter provided) or refunding the purchase price for such Goods theretofore paid by the Buyer, and Buyer’s exclusive remedy for breach of any such warranties will be enforcement of such obligations of Manufacturer. If Manufacturer so requests the return of the Goods, the Goods will be redelivered to Manufacturer in accordance with Manufacturer’s instructions F.O.B. Factory. The remedies contained herein shall constitute the sole recourse of the Buyer against Manufacturer for breach of warranty. IN NO EVENT SHALL MANUFACTURER’S LIABILITY ON ANY CLAIM FOR DAMAGES ARISING OUT OF THE MANUFACTURE, SALE, DELIVERY OR USE OF THE GOODS EXCEED THE PURCHASE PRICE OF THE GOODS. The foregoing warranties will not extend to Goods subjected to misuse, neglect, accident or improper installation or maintenance, or which have been altered or repaired by anyone other than Manufacturer or its authorized representative. THE FOREGOING WARRANTIES ARE EXCLUSIVE AND IN LIEU OF ALL OTHER WARRANTIES OF MERCHANTABILITY, FITNESS FOR PURPOSE OF ANY OTHER TYPE, WHETHER EXPRESS OR IMPLIED. No person may vary the foregoing warranties and remedies except in writing signed by a duly authorized officer of Manufacturer. Warranties or remedies that differ from the foregoing shall not otherwise be binding on Manufacturer. The Buyer’s acceptance of delivery of the Goods constitutes acceptance of the foregoing warranties and remedies, and all conditions and limitations thereof.

1/4" 303 SS, Oval Gear Meter Model TM02C

With only two moving parts and exceptional pressure loss characteristics, Mini Oval is the intelligent approach to metering systems. With flow rates in 0.03-20 GPM range, FPP Meters versatile Mini Oval Series offers either non-factored pulse output or electronic registration.



TM02CSHE
Representative Model

Specifications

- **Flow Rate**
.03-.3 GPM, viscosities to 300 cSt
.1-1.0 lpm, viscosities to 300 cSt
- **Pressure**
400 PSI @ 100°F (28 Bar @ 40°C)
1500 PSI @ 100°F (103 Bar @ 40°C)
- **Temperature**
300°F (149°C) flow sensor without register

Other limits may apply to electronic devices

- **Viscosity**
Full nominal flow rate to 300 CST
Up to 350,000 CST with special gears
- **Connections**
1/4" NPT or BSP
Optional: ANSI flange adaptors
- **Materials**
Case: 303 Stainless Steel
Oval Gears: Ryton™ (PPS)
Posts: 316 Stainless Steel
Seals: Teflon™

Industrial Performance

- **Linearity**
+/- 0.5% @ 1 cSt
- **Repeatability**
+/- 0.25%
- **Resolution**
Flow Sensor: 3550 PPG (938 ppl)
Optional: 7100 PPG (1876 ppl)
- **Calibration**
Electronic: Any unit of mass or volume

Delta P & Accuracy Curves

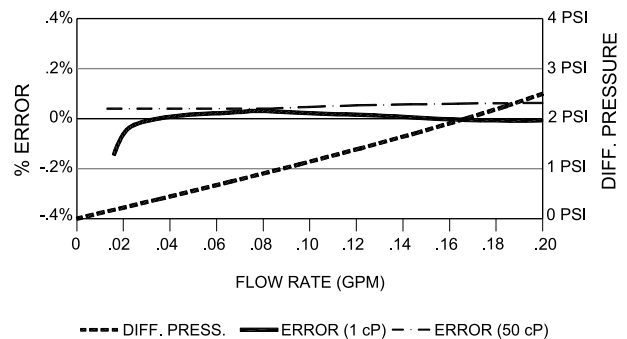

Registration Options

- Battery-powered totalizer or registers
- Communication ports, pump controls
- Unscaled pulse output
- Electronic totalizers/ratemeters
- Electronic batch controllers
- Electronic flow computers
- Electronic mass flow computers
- NEMA 3R, NEMA 4X & NEMA 7/4 enclosures

Accessories

- Pulse amplifiers
- Analog converters

Note: Recommended protection

Inlet strainer, depending upon viscosity, with 80, 100 or 250 mesh basket